

## Saturn 3

SX 475 202-9



### **pole top luminaire**

asymmetric street

LED, 3000 lm, 3000 K, CRI > 80, electronic converter, Total power: 33 W

to be mounted on poles, for spigot  $\varnothing$  76mm, luminaire housing made of die-cast aluminium, powder-coated, screws made of stainless steel, thread with insert sleeves made of stainless steel, cylinder made of PC, clear, Optical system: Tritec Sky silver double, combined lens- and reflector-optics  
incl. 6m feed cable,

CE, IK10, IP65, Protection Class II, optional I

colour: Selux Graphite or special finish

Height H: 535 mm

Diameter  $\varnothing$ : 520 mm

Weight: 9,5 kg

Windpressure: 0,212 m<sup>2</sup>

for spigot:  $\varnothing$  76 mm

Make: Selux, Type: SX 475 202-9

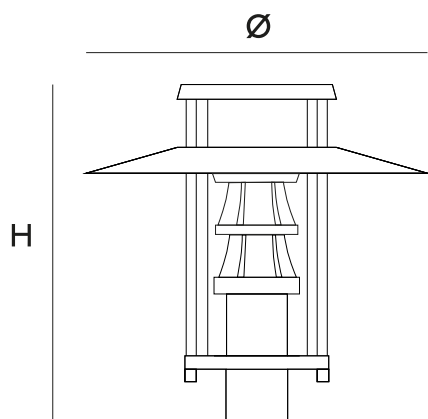

Modifications are possible due to the constant development and improvement of LED technology.

© Selux AG, Subject to technical modification 6.2025

Selux GmbH, Volkmarstr. 18, 12099 Berlin, T +49 30 72001-0, F -100, info@selux.com, www.selux.com

# Saturn 3

## SX 475 202-9

### Technics

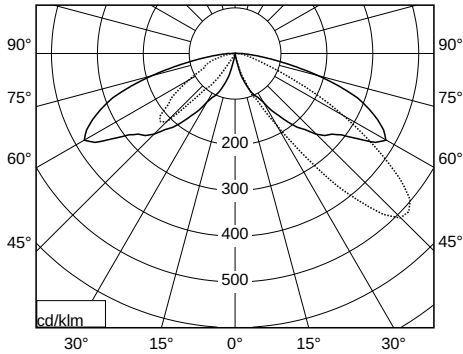

Photometric data: 8715  
 Upward light ratio (ULR): 0.7 %

### Lamp

LED 3000lm, 33W, 3000 K, CRI > 80

### Optic

Tritec Sky silver double, combined lens- and reflector-optics · asymmetric street

### Electrics

electronic converter · Total power: 33W ·  
 6m feed cable  
 control options:  
 dynamic · DALI · fix value · CLT · HNS ·  
 AmpDim · individual power reduction in 300  
 lumen steps ex work · optional Zhaga  
 interface in the luminaire's diffuser shape  
 for Smart City applications

### Luminous flux characteristics / Operating time of LED

	20000	40000	60000	80000	100000
Operating time LED					
Lumen maintenance	99%	97%	96%	95%	93%
LLMF*	0.99	0.97	0.96	0.95	0.93

\* = Lamp lumen maintenance factor

Modifications are possible due to the constant development and improvement of LED technology.

© Selux AG, Subject to technical modification 6.2025

Selux GmbH, Volkmarstr. 18, 12099 Berlin, T +49 30 72001-0, F -100, info@selux.com, www.selux.com